

PlateRite 8600MII-S/E

Thermal Plate Recorder



Creating a Future in Print

PlateRite 8600MII-S/E

The PlateRite 8600MII is a high-quality, entry-level CtP recorder that will provide the foundation for a fully digital platemaking workflow.



Faster turnaround *plus* improved quality and lower costs

CtP benefits

1. Improved registration and press productivity
2. Reduced turnaround times from the shortened production process
3. Cost reduction through the elimination of film processing
4. Sharper, more accurate dots
5. More consistent quality and reduced labor costs

Conventional

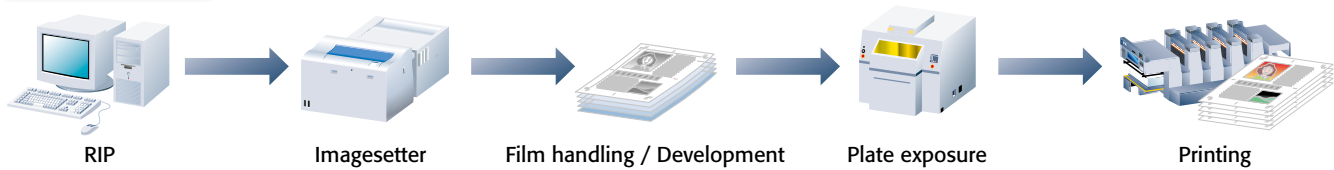

CtP

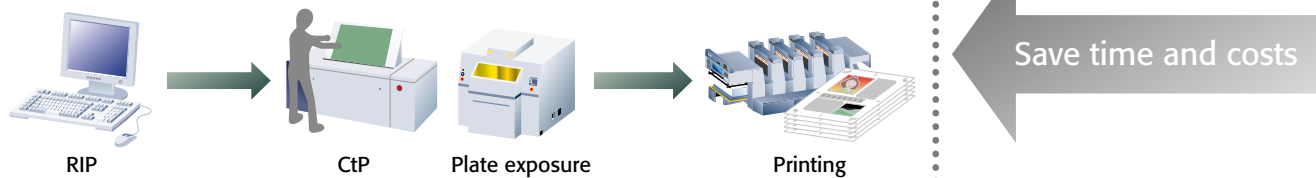

Full-digital workflow

EQUIOS (Workflow system)

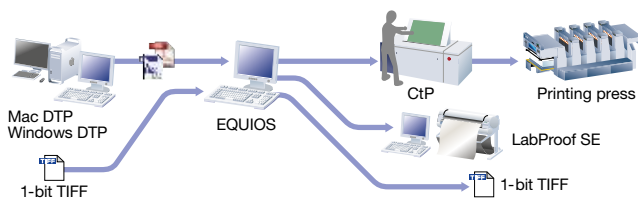

An EQUIOS workflow system helps to achieve maximum productivity. Linking with EQUIOS enables non-stop automation while minimizing errors and production losses. Output to a CtP recorder is also easier than ever before.

Based on international standards

The PlateRite 8600MII conform to specified safety standard.

- Mechanical safety (IEC 60204-1)
- Safety of a laser product (IEC 60825-1)

The PlateRite 8600MII is produced at an ISO-certified factory.

- ISO 9001 (2005/12)
- ISO 14001 (2007/11)

The PlateRite 8600MII is another high-quality thermal CtP recorder built with the renowned technology and expertise that have made Dainippon Screen the world's number one CtP manufacturer. Screen's unique thermal external drum technology is combined with its high-precision optics to enable fast and high-quality plate output. As there is no need for complex processing and intermediate steps, such as outputting layout data to film or exposing plates using film, the plate production process with CtP is much simpler than traditional platemaking.

Furthermore, CtP eliminates paste-up errors and foreign-matter contamination, contributing to increased efficiency in both the platemaking and printing process. Last but not least, thermal CtP output produces sharper halftone dots than traditional platemaking methods, and therefore dramatically improves printing quality.

Screen's technologies

Optical system technology

Stable exposure beam

With the PlateRite 8600MII, the exposure head and its built-in laser move as a single unit. This prevents any profile fluctuation caused by changes in the shape of the optical fiber and produces a stable beam.

PlateRite 8600MII

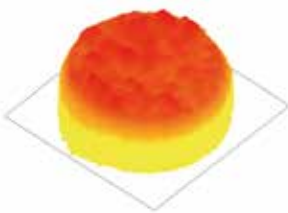

The laser is included in the exposure head to produce a stable beam.

Products from other companies

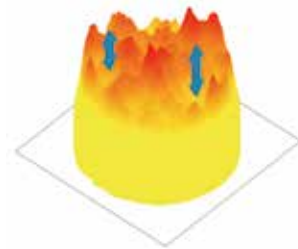

Unevenness occurs in the power distribution of the beam, creating instability.

Fine imaging lens

The PlateRite 8600MII capitalizes on Screen's advanced optical technology. It features high refractive index glass and an impressive 13 element lens design for sharper imaging of half-tone dots. Proprietary technology also compensates for shifts in the focal position caused by environmental temperature variations.

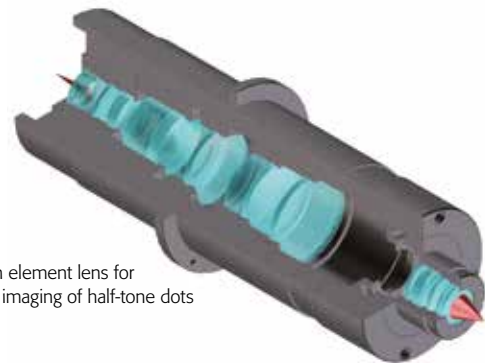

Thirteen element lens for sharper imaging of half-tone dots

Drum technology

Reliable plate securing system

The PlateRite 8600MII recorder features an automated clamping and vacuum system. This system can consistently and firmly secure a wide range of plate sizes, even during fast-rotation/high-speed exposure. A plate is fixed to the drum by a unique slot equipped with a clamp and a vacuum attachment system.

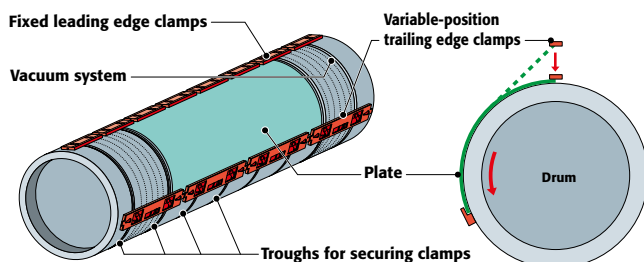

Auto-balance system

The PlateRite 8600MII features Screen's unique and precise auto-balance system. It ensures the counter weights automatically adjust with every change of plate size, maintaining smooth and silent drum rotation. This system is easy to set up via the display menu without any technical intervention.

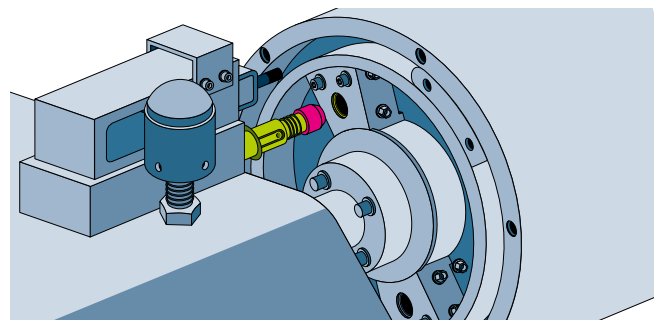

Dimensions

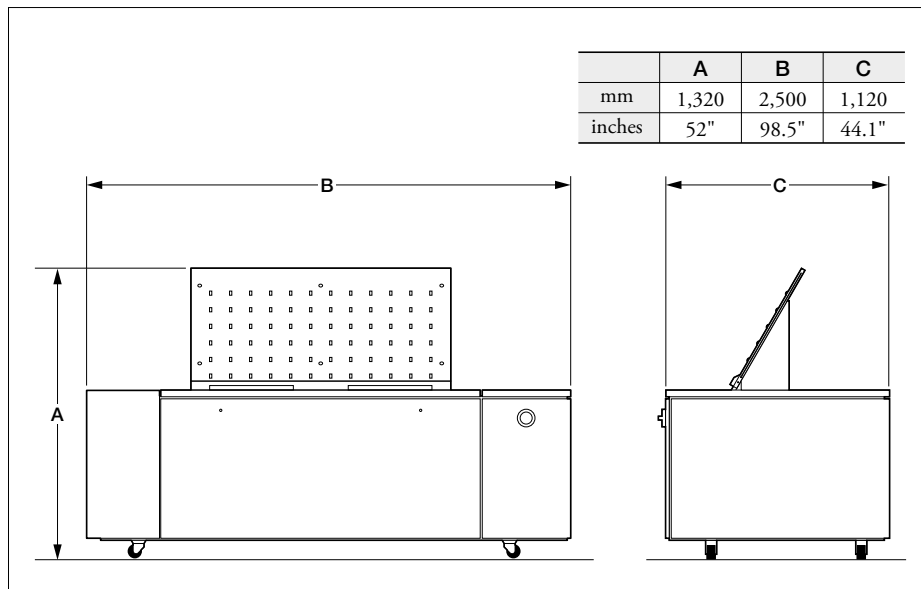

Universal, compact design

Equipment height enables easy operation.

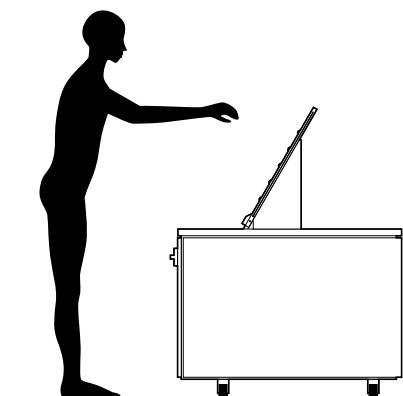

PlateRite 8600MII specifications

Product name	PlateRite 8600MII-S	PlateRite 8600MII-E
Model name	PT-R8600MII-S	PT-R8600MII-E
Recording system	External drum	
Light source	64-channel laser diodes	32-channel laser diodes
Plate size	Maximum 1,060 x 830 mm (41.7" x 32.6"); Minimum 450 x 370 mm (17.8" x 14.6")	
Exposure size	Maximum 1,060 x 806 mm (41.7" x 31.7") [Maximum 1,060 x 806 mm (41.7" x 31.7") at 900 rpm; Maximum 1,060 x 810 mm (41.7" x 31.8") at 600 rpm]	
Plate	Thermal aluminum plate	
Plate thickness	0.15 to 0.3 mm (6 to 11.8 mil)	
Resolutions	1,200/2,400/2,540 dpi *1	
Repeatability	± 5 µm *2	
Productivity	20 plates/hr (1,030 x 800 mm/40.5" x 31.4" plates) at 2,400 dpi *3 *4	13 plates/hr (1,030 x 800 mm/40.5" x 31.4" plates) at 2,400 dpi *3 *4
Interface	F-PIF	
Plate transport	Semiautomatic loading	
Dimensions (W x D x H)	Main Unit: 2,500 x 1,120 x 1,320 mm (98.5 x 44.1" x 52")	
Weight	Main Unit: 880 kg (1,930 lb)	
Power requirements	Main unit: Single phase 200 V to 240 V, 30 A, 4.0 kW	
Environment	Recommended: 21 to 25°C (69.8 to 77°F); Required: 18 to 26°C (64.4 to 78.8°F); Relative humidity: 40 to 70% (no condensation)	
Applicable standard	Conform to IEC 60204-1, IEC60825-1	

*1. 1,200 dpi uses 2,400 dpi double dots.

*2. Over four consecutive exposures on one plate at 23°C (73.4°F) and 60% relative humidity.

*3. Productivity may vary depending upon media sensitivity.

*4. Productivity is calculated so it includes 10 seconds for loading and unloading per plate.

www.screen.co.jp/ctp_no1

For more information, please visit our web site.
You can see product movie on it!



DAINIPPON SCREEN MFG. CO., LTD.

HEAD OFFICE

• Teranouchi-agaru 4-chome, Horikawa-dori, Kamigyo-ku, Kyoto, 602-8585 Japan/Phone +81-75-414-7610/Fax +81-75-414-7608

DAINIPPON SCREEN GRAPHICS (USA), LLC

• 5110 Tollview Dr., Rolling Meadows, IL 60008, USA/Phone +1-847-870-7400/Fax +1-847-870-0149 www.screenusa.com

DAINIPPON SCREEN (DEUTSCHLAND) GmbH

• Mündelheimer Weg 39, 40472 Düsseldorf, Germany/Phone +49-211-472701/Fax +49-211-4727199

DAINIPPON SCREEN (NETHERLAND) B.V.

• Ebuwenj 46, 1185 XX Amstelveen, Holland/Phone +31-20-4567800/Fax +31-20-4567805 www.screeneuropa.com

U.K. office/Phone +44-1582-72-5400/Fax +44-1582-72-5405

DAINIPPON SCREEN SINGAPORE PTE. LTD.

• 29, Kaki Bukit View, Kaki Bukit Techpark II, Singapore 415963/Phone +65-6749-3833/Fax +65-6749-9010 www.screenesp.com.sg

DAINIPPON SCREEN (CHINA) LTD.

• Room 2001 - 2003, 20/F Cable TV Tower 9 Hoi Shing Road Tsuen Wan, N.T. Hong Kong/Phone +852-2953-0038/Fax +852-2755-8683

Beijing office/Phone +86-10-6708-9271, 9272, 9273/Fax +86-10-6708-9395

Shanghai office/Phone +86-21-3126-5122/Fax +86-21-5218-2199

Guangzhou office/Phone +86-20-3891-1112/Fax +86-20-3891-1036

DAINIPPON SCREEN (TAIWAN) CO., LTD.

• 4F No. 126-1, Ming Tsi West Rd., Taipei, Taiwan/Phone +866-2-25862711/Fax +866-2-25914367

DAINIPPON SCREEN (KOREA) CO., LTD.

• 10th Yonsei Bongnae B/D 48-3, 1Ga, Bongnae-Dong, Joong-Gu, Seoul 100-161, Korea/Phone +82-2-7766-786/Fax +82-2-7766-787

DAINIPPON SCREEN (AUSTRALIA) PTY. LTD.

• Suite 11, 2 Eden, Park Drive, Macquarie, NSW2133, Australia/Phone +61-2-9016-3400/Fax +61-2-9016-3425

Internet web site : www.screen.co.jp

www.screenusa.com

www.screeneuropa.com

• This brochure was made using SPEKTA 2 screening.

We reserve the right to alter product design and specifications without prior notice.

No.205-152E Printed in Japan 02-14 020PSI(R0-0)